

107470

WELDING & CUTTING

Portable Torch Kit with Oxygen & Acetylene Tanks

⚠ DANGER

Read this material before using this product.

Failure to do so can result in
serious injury or DEATH.

SAVE THIS MANUAL.



Regulators	Oxygen: CGA 540 Acetylene: CGA 200
Welding Nozzle	VM-W, welds up to 1/16 IN.
Cutting Tip	3-101, cuts up to 1/2 IN.
Hose Size	12.5 FT. L x 3/16 IN. inside diameter
Hose type	Color coded Twin Hose (green: oxygen, red: acetylene)
Torch Inlet Thread	9/16 IN. x 18
Hose Fitting Threads	Oxygen: Right-Hand Acetylene: Left-Hand
Cylinders not included	20 CU. FT. oxygen 10 CU. FT. acetylene
Accessories	Goggles, Spanner, Tip cleaner Striker

Capable of welding from 1/32" up to 1-1/4" with the appropriate welding nozzle.
Capable of cutting from 1/2" up to 3" with the appropriate cutting tip.

Will cut up to 1/2" and weld up to 1/16" with the included welding and cutting tips.
Larger welding and cutting tips are sold separately.

All Rights reserved. No portion of this manual or any artwork contained herein may be reproduced in any shape or form without the express written consent of us. Diagrams within this manual may not be drawn proportionally. Due to continuing improvements, actual product may differ slightly from the product described herein. Tools required for assembly and service may not be included.

Save This Manual

Keep this manual for the safety warnings and precautions, assembly, operating, inspection, maintenance and cleaning procedures. Write the product's serial number in the back of the manual near the assembly diagram (or month and year of purchase if product has no number). Keep this manual and the receipt in a safe and dry place for future reference.

IMPORTANT SAFETY INSTRUCTIONS

In this manual, on the labeling, and all other information provided with this product:



This is the safety alert symbol. It is used to alert you to potential personal injury hazards. Obey all safety messages that follow this symbol to avoid possible injury or death.

⚠ DANGER

DANGER indicates a hazardous situation which, if not avoided, will result in death or serious injury.

⚠ WARNING

WARNING indicates a hazardous situation which, if not avoided, could result in death or serious injury.

⚠ CAUTION

CAUTION, used with the safety alert symbol, indicates a hazardous situation which, if not avoided, could result in minor or moderate injury.

NOTICE

NOTICE is used to address practices not related to personal injury.

CAUTION

CAUTION, without the safety alert symbol, is used to address practices not related to personal injury.

Safety Warnings



WARNING Read all safety warnings and instructions. Failure to follow the warnings and instructions may result in explosion, fire and/or serious injury. Save all warnings and instructions for future reference.

The warnings, precautions, and instructions discussed in this instruction manual cannot cover all possible conditions and situations that may occur. It must be understood by the operator that common sense and caution are factors which cannot be built into this product, but must be supplied by the operator.

Work Area Safety

- Keep your work area clean and well lit.** Cluttered benches and dark areas invite accidents.
 - Keep bystanders, children, and visitors away while operating.** Distractions can cause you to lose control. Protect others in the work area from intense heat. Do not allow others close enough to look at the flame as eye damage is a real possibility. Provide barriers or shields as needed.
 - When possible, move the work to a location well away from combustible materials.** If relocation is NOT possible, protect the combustibles with a cover made of fire resistant material. Remove or make safe all combustible materials for a radius of 35 feet (10 meters) around the work area.
 - Enclose the work area with portable fire resistant screens.** Use a fire resistant material to block all openings and protect combustible walls, ceilings, floors, etc.
 - If working near/on a metal wall, ceiling, floor, etc., prevent ignition of combustibles on the other side by moving the combustibles to a safe location.** If relocation of combustibles is NOT possible, designate someone to act as a fire watch equipped with a fire extinguisher during the welding or cutting process and for at least one half hour after the welding or cutting project is completed.
 - Do not place the Torch on any material other than bare concrete until it has cooled completely.**
 - Do not weld or cut any material that has a combustible coating or a combustible internal structure, such as drums or tanks, without an approved method for eliminating the hazard.**
 - Do not dispose of hot slag in containers holding combustible materials.**
 - Keep a fully charged fire extinguisher close by and know the proper way to use it.**
- After welding or cutting make a thorough check for evidence of fire and be aware the easily visible flame or smoke may not be present for some time after a fire has started.**
- Do not weld or cut in atmospheres containing dangerously reactive or flammable gases, vapors, liquids, or dust.**

Parts List and Assembly Diagram

Part	Description	Qty
1	Carry Tote	1
2	Google	1
3	Lighter	1
4	Hose Assembly	1
5	Cutting Attachment	1
6	Cutting Tip	1
7	Torch Handle	1

Part	Description	Qty
8	Welding Nozzle	2
9	Oxygen Regulator	1
10	Acetylene Regulator	1
11	Tip Cleaner	1
12	Wrench	1
13	Oxygen Cylinder	1
14	Acetylene Cylinder	1

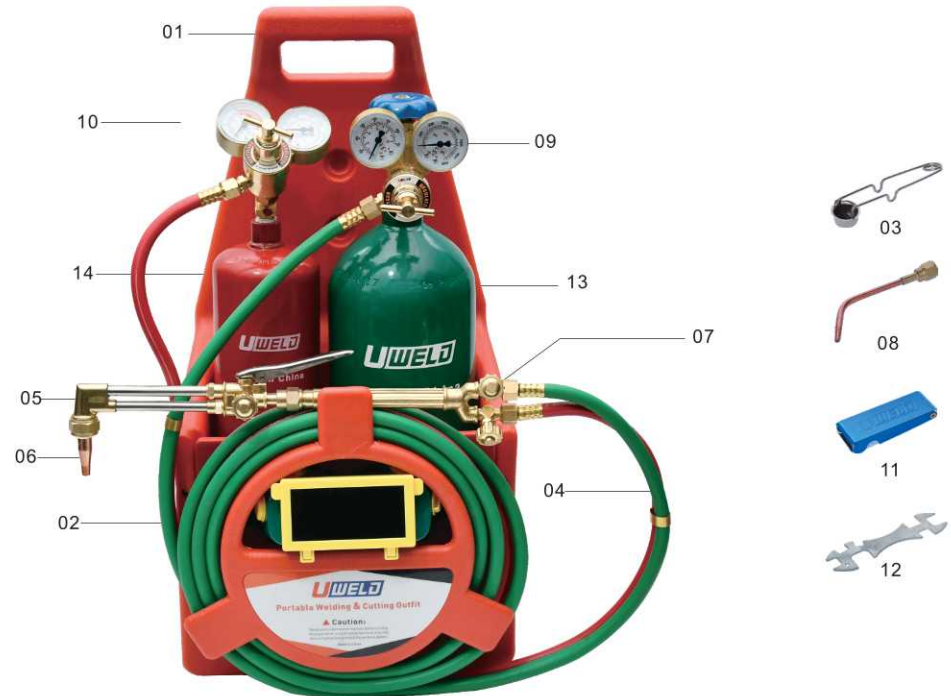

Record Product's Serial Number Here: _____

Note: If product has no serial number, record month and year of purchase instead.

Note: Some parts are listed and shown for illustration purposes only, and are not available individually as replacement parts.

PLEASE READ THE FOLLOWING CAREFULLY

THE MANUFACTURER AND/OR DISTRIBUTOR HAS PROVIDED THE PARTS LIST AND ASSEMBLY DIAGRAM IN THIS MANUAL AS A REFERENCE TOOL ONLY. NEITHER THE MANUFACTURER OR DISTRIBUTOR MAKES ANY REPRESENTATION OR WARRANTY OF ANY KIND TO THE BUYER THAT HE OR SHE IS QUALIFIED TO MAKE ANY REPAIRS TO THE PRODUCT. OR THAT HE OR SHE IS QUALIFIED TO REPLACE ANY PARTS OF THE PRODUCT. IN FACT, THE MANUFACTURER AND/OR DISTRIBUTOR EXPRESSLY STATES THAT ALL REPAIRS AND PARTS REPLACEMENTS SHOULD BE UNDERTAKEN BY CERTIFIED AND LICENSED TECHNICIANS, AND NOT BY THE BUYER. THE BUYER ASSUMES ALL RISK AND LIABILITY ARISING OUT OF HIS OR HER REPAIRS TO THE ORIGINAL PRODUCT OR REPLACEMENT PARTS THERETO, OR ARISING OUT OF HIS OR HER INSTALLATION OF REPLACEMENT PARTS THERETO.

Maintenance Instructions



Procedures not specifically explained in this manual must be performed only by a qualified technician.

WARNING

TO PREVENT SERIOUS INJURY FROM ACCIDENTAL OPERATION:
Close the oxygen, then acetylene and allow the torch to cool completely, then disconnect the hoses before performing any inspection, maintenance, or cleaning procedures.

TO PREVENT SERIOUS INJURY FROM TOOL FAILURE:
Do not use damaged equipment. If abnormal noise, vibration, or leaking gas occurs, have the problem corrected before further use.

- BEFORE EACH USE**, inspect the general condition of the Torch Kit. Check for loose hose connections, cracked or worn hoses, and any other condition that may affect its safe operation.
If any abnormal condition occurs or is noticed, have the problem corrected before further use.
Do not use damaged equipment.
- Periodically use a tip cleaner to clean out Cutting Tip and Welding Nozzle.
- To clean the outer body of the Cutting Attachment, use a clean, dry, cloth. Do not immerse any part of the Cutting Attachment in ANY liquid.
Do not use solvents or other flammable agents to clean the Cutting Attachment.

MAINTENANCE CHART		
Maintenance Type	Before Use	After Use
Inspect tool for damage.	X	X
Use tip cleaner to clean tip opening.	X	X
Wipe off with clean, dry cloth. NEVER USE SOLVENTS TO WIPE DOWN THIS CUTTING ATTACHMENT.		X

Troubleshooting

Problem	Possible Causes	Likely Solutions
Before turning on Torch, gas odor is noticed.	<ol style="list-style-type: none"> Hose connections loose. Crack in hose. Cylinder leak at neck. 	<ol style="list-style-type: none"> Tighten all connections. Check hoses. If any cracks are found, replace entire hose. DO NOT PATCH OR TAPE GAS HOSES. Check neck area of cylinders. If cracks or damage are found, do not use. Secure upright, in a well-ventilated area, well away from sources of ignition. Contact gas supplier IMMEDIATELY. Replace cylinders before proceeding with work.
Flame is irregular.	<ol style="list-style-type: none"> Cutting tip clogged or dirty. Gas low. 	<ol style="list-style-type: none"> Close gas, oxygen first, then acetylene. Let Torch cool completely. Remove Tip, check for dirt and debris. Use tip cleaner to clean Tip or replace if necessary. Check gas level and refill if needed.



Follow all safety precautions whenever diagnosing or servicing the tool.
Disconnect air supply before service.

- Clean and purge containers before applying heat.**
Do not apply heat to a container that has held an unknown substance or a combustible material whose contents, when heated, can produce flammable or explosive vapors. Vent closed containers, including castings, before preheating, welding, or cutting.

Personal Safety

- Wearing and using personal safety clothing and safety devices reduce the risk of injury. Wear the following:**
 - Fire-resistant clothing** (Do not wear pants with cuffs, shirts with open pockets, or any clothing that can catch and hold molten metal or sparks.)
 - Fire-resistant leather leggings and work boots**
 - Dry, insulating leather welding gloves**
 - NIOSH-approved respirator**
 - Shade 5 or higher welding goggles**
 - Appropriate head covering to protect head and neck**
 - Fire-resistant ear plugs or ear muff (if welding or cutting overhead or in confined spaces)**

Keep clothing and safety equipment free of grease, oil, solvents and any other flammable substances.

- Stay alert. Watch what you are doing, and use common sense when operating this Torch. Do not use while tired or under the influence of drugs, alcohol, or medication.**
A moment of inattention while operating may result in serious personal injury.
- Do not overreach. Keep proper footing and balance at all times.** Proper footing and balance enables better control in unexpected situations.

- INHALATION HAZARD: Welding and Cutting Produce TOXIC FUMES.**



Exposure to welding or cutting exhaust fumes can increase

the risk of developing certain cancers, such as cancer of the larynx and lung cancer. Also, some diseases that may be linked to exposure to welding or cutting exhaust fumes are:

- Early onset of Parkinson's Disease
- Heart disease
- Kidney damage
- Respiratory diseases such as emphysema, bronchitis, or pneumonia
- Ulcers



Use natural or forced air ventilation and wear a respirator approved by NIOSH to protect against the fumes produced to reduce the risk of developing the above illnesses.

- Avoid overexposure to fumes and gases. Keep your head out of the fumes. Do not breathe fumes. Use enough ventilation or exhaust, or both to keep fumes and gases away from your breathing area. Where ventilation is questionable, have a qualified technician take an air sampling to determine the need for corrective measures. If necessary, use mechanical ventilation to improve air quality. If this is not possible, use an approved respirator. Do not work in confined areas unless they are well-ventilated or you are wearing an air supplied ventilator. Always follow OSHA guidelines for Permissible Exposure Limits (PEL's) for various fumes and gases. Follow the American Conference of Governmental Industrial Hygienists recommendations for the Threshold Limit Values (TLV's) for fumes and gases. Have a recognized specialist in Industrial Hygiene or Environmental Services check the operation and air quality and make recommendations for the specific welding or cutting situation.
- WARNING:** This product, when used for welding, cutting, soldering, or similar applications, produces chemicals known to the State of California to cause cancer and birth defects (or other reproductive harm). (California Health & Safety Code § 25249.5, et seq.)
The brass components of this product contain lead, a chemical known to the State of California to cause birth defects (or other reproductive harm). (California Health & Safety Code § 25249.5, et seq.)

Equipment Setup Safety

- Make sure you are prepared to begin work before opening gas supply.**
- To prevent explosion, use reverse-flow check valves and flashback arrestors (sold separately) on the base of the Torch.**
- Use with oxygen and acetylene only.**
Do not modify this torch or use it for a purpose for which it is not intended.
- Set Acetylene Regulator no greater than 15 PSI.**
Acetylene is unstable and can explode if over-pressurized.
- Do not use oil, grease or thread seal tape on any connector.**
- Use clamps (not included) or other practical ways to secure and support the work piece to a stable platform.** Holding the work by hand or against your body is unstable and may lead to loss of control, fire and/or personal injury.
- Use only accessories that are recommended by the manufacturer for your model Torch.**
Accessories that may be suitable for one Torch may become hazardous when used on another Torch. Only use proper gas hoses.

Cylinder Safety

1. **Do not use dented or damaged cylinders.**
2. **Secure cylinders to a cart, wall, or post to prevent them from falling.**
Use and store cylinders in an upright position only. If using the included case to hold the cylinders, secure the case to a cart, wall or post.
3. **Use cylinder caps when moving or storing cylinders.**
4. **Do not store cylinders in temperatures 120° F or higher.**
5. **EMPTY CYLINDERS: DO NOT DROP, STRIKE, PUNCTURE, HEAT OR SET FIRE TO A CYLINDER, EVEN IF IT IS EMPTY.** Keep empty cylinders in specified areas and clearly mark "empty". Contact local solid waste authorities for instructions on correct disposal or recycling of empty cylinders.
6. **KEEP WRENCH ON ACETYLENE CYLINDER'S VALVE whenever cylinder is in use to allow quick shutoff in case of emergency.**

Equipment Inspection

1. **DO NOT USE FLAME TO DETECT LEAKS.**
2. **INSPECT BEFORE EVERY USE. Look for the following, and do not use kit if any damage is noted:**
 - a. **Inspect the tapered seating surfaces on the Nozzles, and the Tip Nut.** Have a qualified technician resurface the seat area if it has dents, burrs, or is burned. A poor seating surface may result in backfire or flashback.
 - b. **Examine all hoses for cuts, cracks, burns, worn areas, or other damage.** Do not use if damaged.
 - c. **Check for loose connections using soapy water solution.** Tighten or repair any leaks found.
 - d. **Do not use the Torch Kit if either gas does not turn off completely when the Oxygen Torch Valve and Acetylene Torch Valve are closed.** Leakage of gas from the tip is a substantial safety risk. If gas cannot be turned off at the Torch Handle, it is dangerous and must be replaced.
 - e. **Inspect for any other defects or damage.** Do not use any damaged parts. Tag damaged parts "Do not use" until repaired.

Operation Safety

1. **Inspect before every use, see previous warning section.**
2. **Use only with proper ventilation.**
3. **Do not touch workpiece or tip until cool.**
4. **Keep hoses away from hot parts, from cut area, and from flame.**
5. **Never leave the Torch unattended when it is attached to a gas supply.**
6. **Allow sufficient time for the Torch to completely cool before storing.**
7. **Any material discharged from the work area during use will be extremely hot.** Use care to not get burned by slag or other waste products.
8. **BACKFIRE: When the flame goes out with a loud "pop", it is called a backfire.** Backfire can be caused by:
 - a. Operating the Torch at lower pressures than required for the Tip used.
 - b. Touching the Tip against the workpiece.
 - c. Overheating the Tip.
 - d. An obstruction in the Tip.
If backfire occurs, close the Torch Handle Valves (oxygen first, then acetylene) and after remedying the cause, relight the torch.
9. **FLASHBACK:** Flashback is a condition that results when the flame flashes back into the Torch and burns inside with a shrill hissing or squealing noise. **If flashback occurs, close the Torch Handle Valves (oxygen first, then acetylene) IMMEDIATELY!** Flashback generally indicates a problem that should be repaired before proceeding with the job at hand. A clogged Tip, improper functioning of the Valves, or incorrect acetylene/oxygen pressure could lead to flashback. Find and correct the cause before relighting the Torch. If the cause is not found, have the kit serviced by a qualified technician before returning to your project.

Cutting Shutdown Instructions

1. After work is complete, close the Oxygen Torch Valve first clockwise, then close the Acetylene Torch Valve clockwise.
2. Fully close both cylinder valves, turning clockwise.

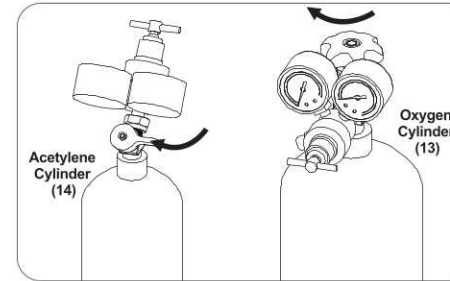
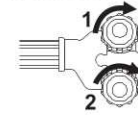

Shutdown Step 2: Close Cylinder Valves

3. Open the Acetylene Torch Valve counterclockwise to allow all the pressure to bleed out.

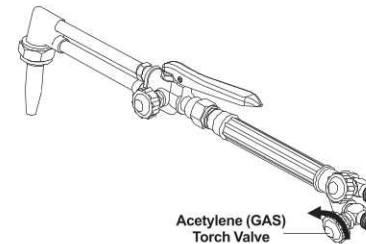

Shutdown Step 3: Open Acetylene Valve

4. Open the Oxygen Torch Valve counterclockwise and open the Pre-heat Oxygen Valve counterclockwise to allow all the pressure to bleed out.

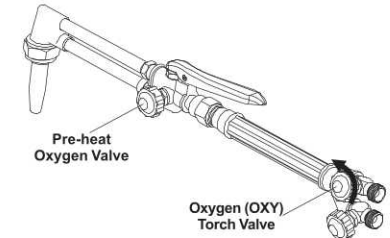

Shutdown Step 4: Open Oxygen Valves

5. After releasing pressure, turn the Pressure Adjusting Screws counterclockwise and remove them from the regulators.

IMPORTANT ! Failure to do this may permanently damage the Regulators.

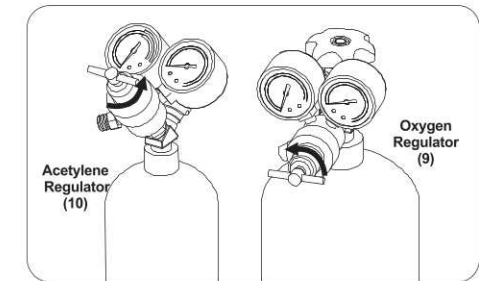

Shutdown Step 5: Close Regulators
(Turn counterclockwise until loose.)

- Open the Acetylene Torch Valve about 1/4 turn, and quickly ignite the acetylene gas coming out of the Nozzle by squeezing the handle of the striker, creating a spark.

WARNING! Do not use matches or a butane lighter to light the Torch.

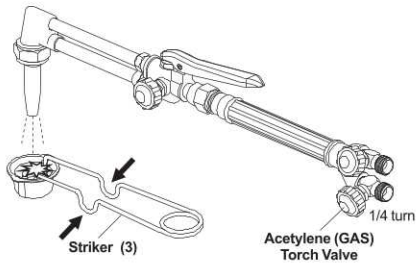

Cutting Step 5: Lighting Acetylene

- Put the striker down on a fireproof surface. Slowly open the Acetylene Torch Valve farther until the flame feathers at its edge slightly, as shown below.



Cutting Step 6: Slowly Open Acetylene Torch Valve Until Flame Feathers

- Do not squeeze the Oxygen Cutting Lever.** Open the Oxygen Torch Valve.

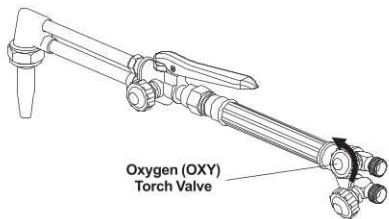

Cutting Step 7: Open Oxygen Torch Valve

- Flame Adjustment:**
 - Starting to Add Oxygen:** Slowly open the Pre-heat Oxygen Valve. The flame will change to a carbonizing flame with a blue/white inner core, a white halo surrounding the core and a light orange flame as shown in Cutting Step 8 illustration, below left.
 - Proper Oxygen Mix:** Continue slowly turning the Pre-heat Oxygen Valve until the large light orange section of the flame becomes nearly colorless and the center of the flame has a white core with little or no halo. **This is the "neutral" flame needed for operation** as shown in Cutting Step 8 illustration, below center.
 - Too Much Oxygen:** If you open the Pre-heat Oxygen Valve too far, the large section of the flame will be bluish-orange and the inner core will be small as shown in Cutting Step 8 illustration, below right. Close the Pre-heat Oxygen Valve slightly until you achieve the flame described in step b above.

WARNING! Wear appropriate welding goggles.

- After the flame is adjusted as explained and illustrated, proceed with cutting:
 - Heat the edge where starting the cut until it is red hot.

WARNING! Start the cut at the edge of the workpiece. If done improperly, attempting to start a cut in the middle of the workpiece will splash molten metal back at the operator. Do not attempt to start a cut in the middle of a workpiece unless properly trained in safe methods of starting these cuts.

 - After preheating, press the Oxygen Cutting Lever and slowly guide the torch along the cut line to cut the metal.

- After cutting, follow shutdown instructions on facing page.

- Beware of leaking gas. If while you are using this Torch you notice the odor of acetylene, IMMEDIATELY close the oxygen first, then the acetylene.** Extinguish all open flames and carefully check all hoses and connections for leaks using soapy water. **NEVER check for leaks using a flame.** If the odor continues do not use the Torch. Call acetylene supplier for assistance.
- Read and understand all instructions and safety precautions as outlined in the manufacturer's manual for the material you will weld or cut.**
- After use, bleed lines and store all components out of reach of children and other untrained persons.** Torches are dangerous in the hands of untrained users.

Service

- Torch service must be performed only by qualified repair personnel.** Service or maintenance performed by unqualified personnel could result in a risk of injury.
- When servicing, use only identical replacement parts. Follow instructions in the "Inspection, Maintenance, and Cleaning" section of this manual.** Use of unauthorized parts or failure to follow maintenance instructions may create a risk of fire or injury.
- Maintain product labels and nameplates.** These carry important information. If unreadable or missing, contact Harbor Freight Tools for a replacement.

 **SAVE THESE INSTRUCTIONS.**

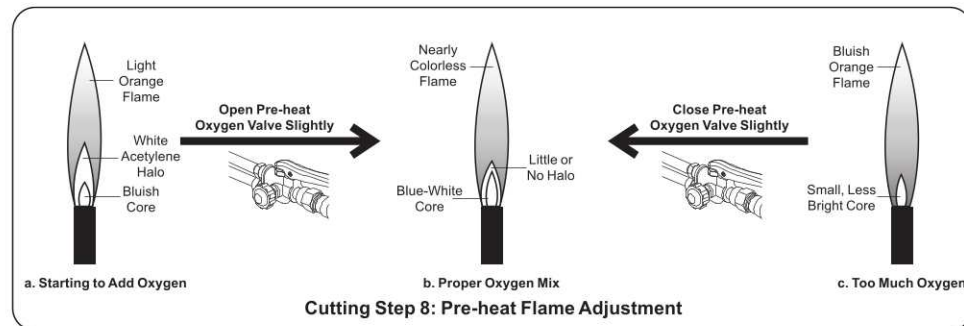

Workpiece and Work Area Setup

1. Designate a work area that is clean and well-lit. The work area must not allow access by children or pets to prevent distraction and injury.
 2. Remove all combustible material from area and/or cover surfaces with fire resistant material.
 3. The work area must have a fireproof floor.
 4. Secure loose workpieces using a vise or clamps (not included) to prevent movement while working.
- Note:** Proper weld preparation can be complicated, and is outside the scope of this manual.

Tool Set Up 1 of 3 - Assembly

! Read the **ENTIRE IMPORTANT SAFETY INFORMATION** section at the beginning of this manual including all text under subheadings therein before set up or use of this product.

! WARNING

TO PREVENT SERIOUS INJURY FROM EXPLOSION: Turn the Oxygen and Acetylene Torch Valves fully clockwise (closed, oxygen first and acetylene second) before making any adjustments or performing any inspection or service to this Torch Kit.

Note: For additional information regarding the parts listed in the following pages, refer to the Assembly Diagram near the end of this manual. All instructions in this manual are for oxygen and acetylene gas only.

1. Secure cylinders to a cart, wall, or post to prevent them from falling. Do not place Acetylene Cylinder on its side.
2. While standing to one side, "crack" each cylinder valve. "Cracking" is to quickly open and close the valve, allowing a small amount of gas to escape and clearing the valve of any foreign material. **WARNING! If oil or grease is found, discontinue using cylinder and immediately contact your gas supplier.**
3. Attach the Green labeled Oxygen Regulator (9) to the Oxygen Cylinder (13) and the green oxygen hose to the regulator.
4. Attach the Red labeled Acetylene Regulator (10) to the Acetylene Cylinder (14) and the red acetylene hose to the regulator, **tighten counterclockwise- threads are reversed.**

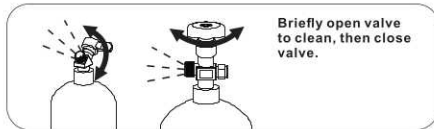

Assembly Step 2: Crack Each Cylinder Valve

WARNING! KEEP WRENCH ON ACETYLENE CYLINDER'S VALVE whenever cylinder is in use to allow quick shutoff in case of emergency.

NOTE: Wrench not included.

Cutting Instructions

! Read the **ENTIRE IMPORTANT SAFETY INFORMATION** section at the beginning of this manual including all text under subheadings therein before set up or use of this product.

! Inspect tool before use, looking for leaking, damaged, loose, and missing parts. If any problems are found, do not use tool until repaired.

1. Set up for cutting according to instructions on pages 6-9.
2. Close all valves on the Torch Handle and Cutting Attachment securely.
3. Adjust the Acetylene and Oxygen Regulators to their proper working pressures, see Table B on page 14. **DO NOT EXCEED 15 PSI ACETYLENE PRESSURE.**

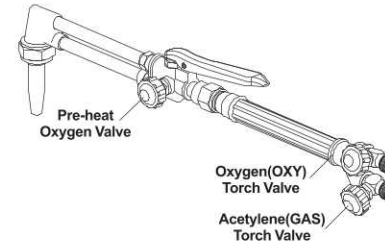

Cutting Step 2: Close Valves

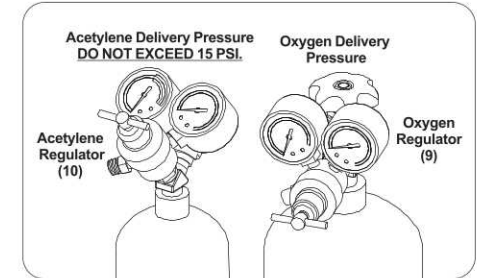

Cutting Step 3: Set Cutting Pressures See Table B on page 14.

4. Hold the Torch Handle in one hand and the striker in the other hand.

Cutting Tip Pressure Settings

The Cutting Attachment is used to cut metal up to 3" thick. The included tip, size 0, cuts metal up to 1/2" thick.

Check the thickness of the metal to be cut and use the chart below to choose the appropriate size tip for the job. If cutting metals over 1/2" thick, a different tip will be needed.

Table B: Cutting Tip Flow Data

Cutting Thickness (inches)	Standard Nozzle Size	Cutting Oxygen Pressure (PSIG)	Acetylene Pressure (PSIG)	Speed (IPM)
1/2	0	30-35	3-5	20-24
3/4	1	30-35	3-5	17-21
1-1/2	2	40-45	3-7	13-17
2-1/2	3	45-50	4-10	10-13
3	4	45-50	5-10	9-12

The Cutting Attachment is attached to the Torch Handle and a Cutting Tip is attached to the end of the Cutting Attachment.

Pre-heat Oxygen Valve: Adjusts pre-heat flame oxygen level.

Oxygen Cutting Lever: Activates extra flow of oxygen for cutting.

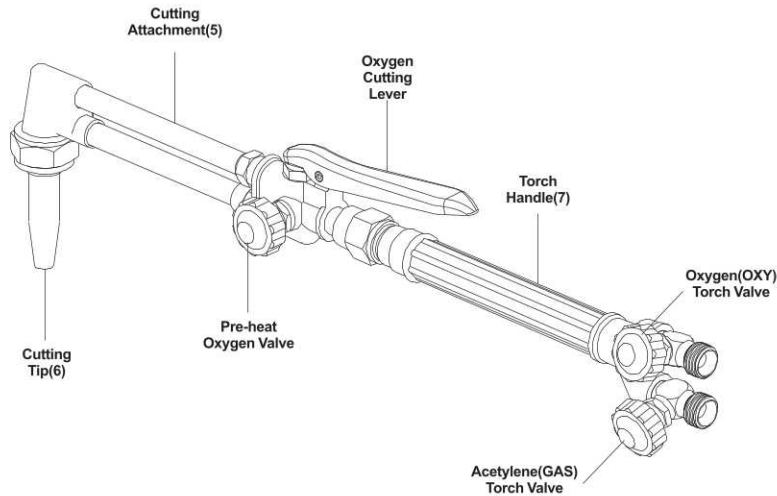

5. To set up the Torch Handle (7):
 - a. Remove the plastic inlet covers.
 - b. Make sure both check valves are in place on the torch handle.
 - c. Connect the green-oxygen hose to the oxygen Check Valve on the Torch Handle.
 - d. Connect the red-acetylene hose to the acetylene Check Valve on the Torch Handle, **tighten counterclockwise threads are reversed.**

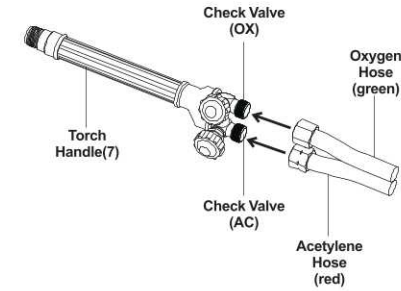

Assembly Step 5: Torch Handle Setup

6b. Cutting Setup

WARNING! BEFORE CONNECTING, make sure the two O-Rings on the end of the Cutting Attachment (5) are not damaged or missing, otherwise gases will mix inside the Torch Handle and result in flashback or backfires.

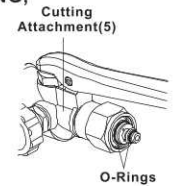

Connect the Cutting Attachment (5) to the Torch Handle. Then, connect the Cutting Tip (6) to the Cutting Attachment (5).

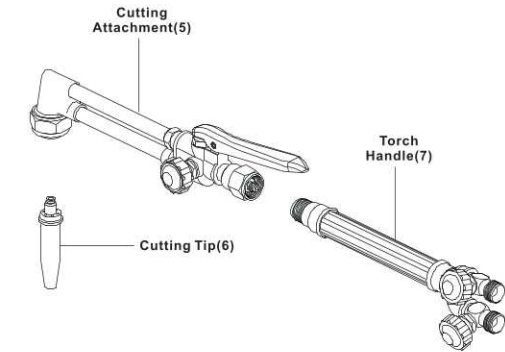

Assembly Step 6a: Cutting Setup

6a. Welding Setup

Connect the Welding Nozzle (8) to the Torch Handle.

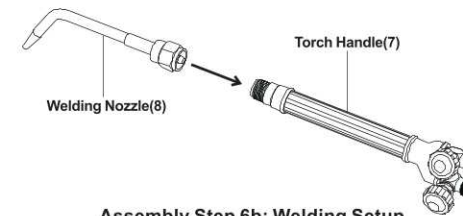

Assembly Step 6b: Welding Setup

7. **Before operation, the leak tests on the following pages must be done after connection to check for leaks in the system.**

Tool Set Up 2 of 3 - First Leak Test: Soapy Water

This test detects major leaks.

- After everything is connected, close both Torch Handle Valves, turning clockwise. Close regulators, turning knobs counterclockwise until loose.

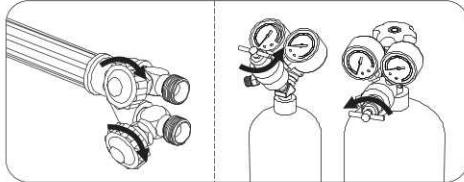

Close Valves
(Turn clockwise)

Close Regulators
(Turn counterclockwise until loose)

Leak Test 1 Step 1

- Open the cylinder valves turning counterclockwise only until the gas starts flowing.

WARNING! Only open Acetylene Cylinder Valve 1/4 to 1/2 turn.

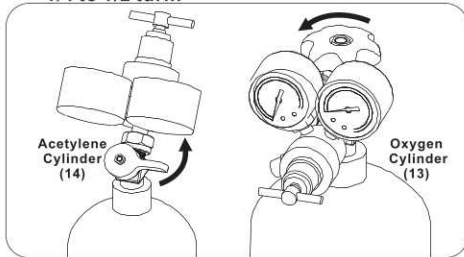

Leak Test 1 Step 2: Open Cylinder Valves

WARNING! KEEP WRENCH ON ACETYLENE CYLINDER'S VALVE whenever cylinder is in use to allow quick shutoff in case of emergency.

- Adjust the oxygen regulator to deliver 20 PSIG. Adjust the acetylene regulator to deliver 10 PSIG. **DO NOT EXCEED 15 PSI ACETYLENE PRESSURE.**

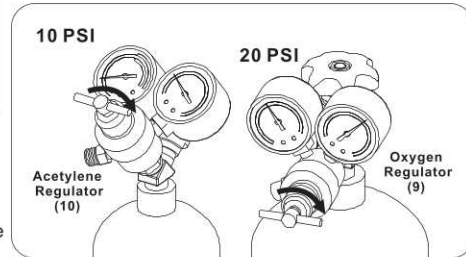

Leak Test 1 Step 3: Set Testing Pressures

- Check all connections for leaks using soapy water:
 - If leaks are found, tighten connections.
 - If a leak persists, discontinue use and call gas supplier.
 - If no leaks are found with this test, move on to the Gauge Monitoring test.

Welding Shutdown Instructions

- After work is complete, close the Oxygen Torch Valve first clockwise, then close the Acetylene Torch Valve clockwise.

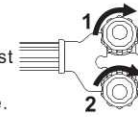

- Fully close both cylinder valves, turning clockwise.

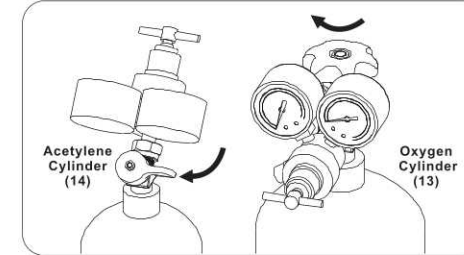

Shutdown Step 2: Close Cylinder Valves

- Open the Acetylene Torch Valve counterclockwise to allow all the pressure to bleed out.

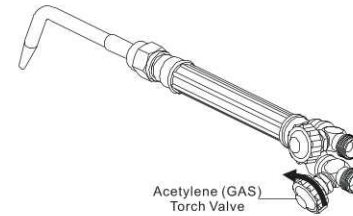

Shutdown Step 3: Open Acetylene Valve

- Open the Oxygen Torch Valve counterclockwise to allow all the pressure to bleed out.

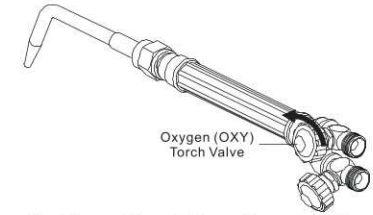

Shutdown Step 4: Open Oxygen Valve

- After releasing pressure, turn the Pressure Adjusting Screws counterclockwise and remove them from the regulators.

IMPORTANT! Failure to do this may permanently damage the Regulators.

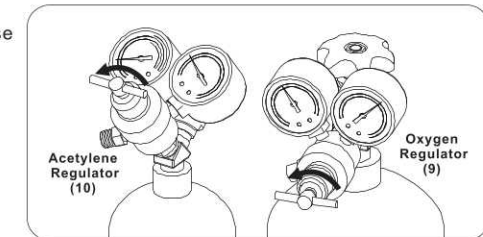

Shutdown Step 5: Close Regulators
(Turn counterclockwise until loose.)

Tool Set Up 3 of 3 - Second Leak Test: Gauge Monitoring

This test detects minor leaks.

- Follow all steps in the Soapy Water test above to prepare for the gauge monitoring test.
- Close both cylinder valves, turning clockwise.

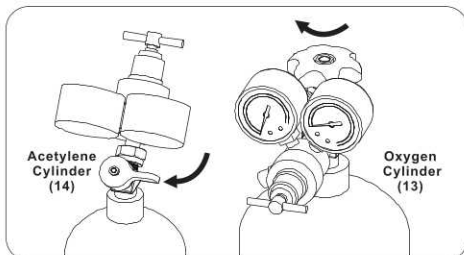

Leak Test 1 Step 2: Open Cylinder Valves

- Monitor gauges on both regulators for five minutes.

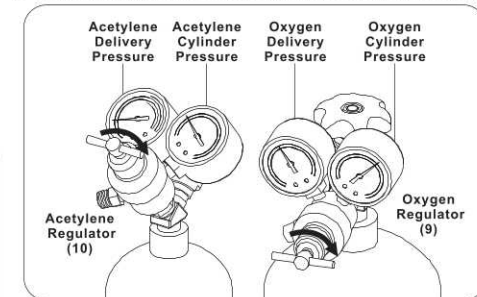

Leak Test 2 Step 3: Monitor Gauges

- If the readings do not change, the test is completed and the system has no leaks.
- If any reading changes, there is a leak on that side of the system. Follow Gauge Leak Analysis on the next page to diagnose.

5. Open the Acetylene Torch Valve about 1/4 turn, and quickly ignite the acetylene gas coming out of the Nozzle by squeezing the handle of the striker, creating a spark.

WARNING! Do not use matches or a butane lighter to light the Torch.

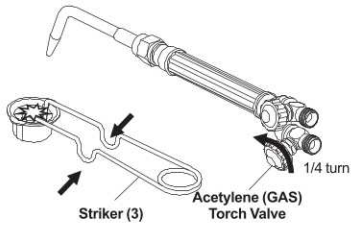

Welding Step 5: Lighting Acetylene

6. Put the striker down on a fireproof surface. Slowly open the Acetylene Torch Valve farther until the flame feathers at its edge slightly, as shown below.



Cutting Step 6: Slowly Open Acetylene Torch Valve Until Flame Feathers

7. Flame Adjustment:
 a. Starting to Add Oxygen: Slowly open the Oxygen Torch Valve. The flame will change to a carbonizing flame with a blue/white inner core, a white halo surrounding the core and a light orange flame as shown in Welding Step 7 illustration, below left.

- b. Proper Oxygen Mix: Continue slowly opening the Oxygen Torch Valve until the large light orange section of the flame becomes nearly colorless and the center of the flame has a white core with little or no halo. **This is the "neutral" flame needed for operation** as shown in Welding Step 7 illustration, below center.

- c. Too Much Oxygen: If you open the Oxygen Torch Valve too far, the large section of the flame will be bluish-orange and the inner core will be small as shown in Welding Step 7 illustration, below right. Close the Oxygen Torch Valve slightly until you achieve the flame described in step b above.

WARNING! Wear appropriate welding goggles.

8. After the flame is adjusted as explained and illustrated, proceed with welding.

Note: Oxygen-acetylene welding is a two-handed process: one hand controls the torch, while the other hand controls a filler rod (sold separately). Proper welding techniques and weld preparation are outside the scope of this manual. Welding books and classes are recommended to teach proper methods and technique.

9. After welding, follow shutdown instructions on facing page.

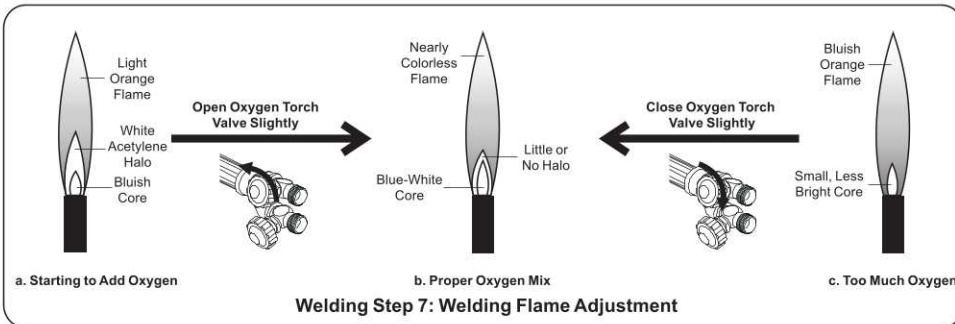

Gauge Leak Analysis

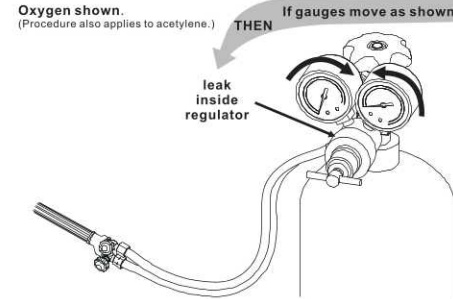

If the Cylinder Pressure decreases and the Delivery Pressure increases
 There is a leak in the regulator seat.

Have the regulator repaired by a qualified technician.

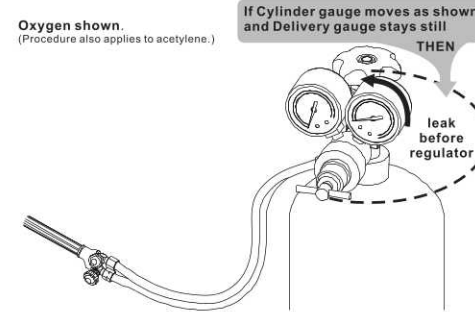

If Cylinder Pressure decreases but the Delivery Pressure remains constant-
 The leak is at cylinder valve or connection between regulator and cylinder valve.



DANGER! To prevent serious injury and DEATH:

DO NOT TIGHTEN OR ADJUST ANY CONNECTION between the cylinder and cylinder valve, or force the cylinder valve.
If the cylinder valve is leaking, move the cylinder outside and notify your gas supplier immediately.

1. Release pressure from the system.
2. Tighten the connection between regulator and cylinder valve.
3. Repeat Gauge Leak Test.
 - a. If the gauges do not change, the test is completed and the system has no leaks.
 - b. If the connection still leaks try with a different cylinder.
 - c. If the connection leaks with the different cylinder, have the regulator examined by a qualified technician.

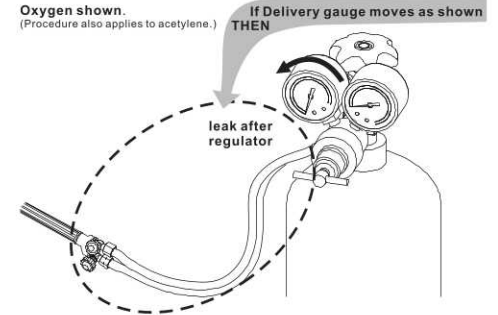

If Delivery Pressure decreases
 The leak is at the regulator outlet connection, within the hose, at the torch inlet connection or at the Torch Valve on the Torch Handle.

1. Release pressure from the system.
2. Tighten the regulator outlet connection.
3. Tighten the Torch Handle Inlet connection.
4. Repeat Gauge Leak Test.
 - a. If the gauges do not change, the test is completed and the system has no leaks.
 - b. If the connections are still leaking, have the regulator, Torch Handle, and hoses examined by a qualified technician. If the hoses are leaking, replace them, do not attempt to repair the hoses.

No Leaks Found

If the leak testing has been completed and the unit is found to be working properly, open the cylinder valves, turning counterclockwise, and proceed to operation. **WARNING!** Only open Acetylene Cylinder Valve 1/4 to 1/2 turn to allow quick shutoff.

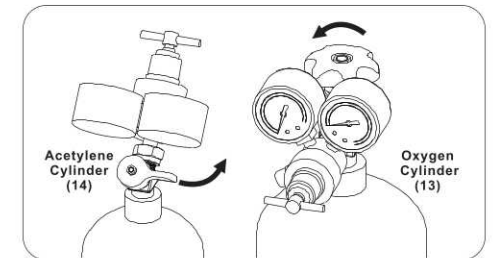

Open Cylinder Valves Only After Testing Confirms There Are No Leaks

WARNING! KEEP WRENCH ON CYLINDER'S VALVE whenever cylinder is in use to allow quick shutoff in case of emergency.

Welding Tip Pressure Settings

This Torch Handle is capable of welding metals from 1/32" up to 1-1/4" thick. The included Welding Nozzle, size 0, will weld metals up to 1/16" thick. Check the thickness of the metals to be welded and use the chart below to choose the size nozzle for the job. If welding metals other than 1/32" to 1/16" thick, a different welding nozzle will be needed.

Note: Welding the thicker metals noted below will require special techniques, such as edge chamfering, that are outside the scope of this manual.

Table A: Welding Nozzle Flow Data

Metal Thickness (inches)	Nozzle Size	Tip Orifice Diameter (inches)	Oxygen Pressure (PSIG)	Acetylene Pressure (PSIG)	Acetylene (CFH)
1/32	000	0.024	3-5	3-5	1-2
3/64	00	0.028	3-5	3-5	1.5-3
1/16	0	0.031	3-5	3-5	1.7-3.4
5/64	1	0.035	3-5	3-5	2-4
3/32	2	0.039	3-5	3-5	3-6
1/8	3	0.051	3-6	3-6	5-10.5
1/4	4	0.067	4-6	4-6	8.5-19
3/8	5	0.079	5-7	5-7	11.5-26
1/2	6	0.091	6-8	5-8	15-35
1-1/4	7	0.126	8-10	8-10	30-60

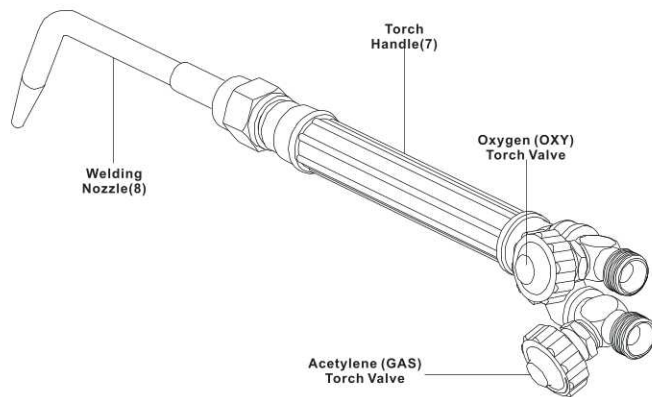

Welding Instructions



Read the **ENTIRE IMPORTANT SAFETY INFORMATION** section at the beginning of this manual including all text under subheadings therein before set up or use of this product.

Inspect tool before use, looking for leaking, damaged, loose, and missing parts. If any problems are found, do not use tool until repaired.

1. Set up for cutting according to instructions on pages 6-9.
2. Close both valves on the Torch Handle securely.
3. Adjust the Acetylene and Oxygen Regulators to their proper working pressures, see Table A on page 10. **DO NOT EXCEED 15 PSI ACETYLENE PRESSURE.**

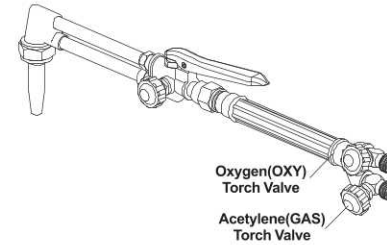

Welding Step 2: Close Valves

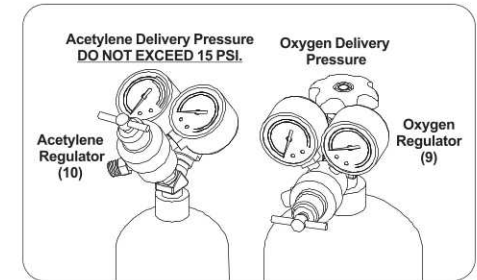

Welding Step 3: Set Welding Pressures
See Table B on page 10.

4. Hold the Torch Handle in one hand and the striker in the other hand.